



KiNEDx

Laboratory Robot



KiNEDx: KX-300-660-SGP



Random Access Plate Hotels



High Capacity Storage Carousel



FILO Plate Stacks

KiNEDx

Robot: The KiNEDx cylindrical robot is a four-axis manipulator offering high payload and excellent repeatability in a very compact and industrialized package.

Geometry: The innovative tri-link arm can retract in on itself to clear peripheral equipment and also provides a superior extended reach.

Software: Control is highly adaptive thanks to the open-architecture software. A full-featured DLL is provided and several options for integration and scheduling are available.

Controller: There is no separate controller required. All joints are servo'd using integral controllers and motors. A single serial cable connects to the user PC. A tethered pendant is used for jogging and teaching.

Applications: Designed for long-term demanding applications, these robots are perfect for many laboratory automation applications including drug discovery, genomics, and HTS (high throughput screening.)

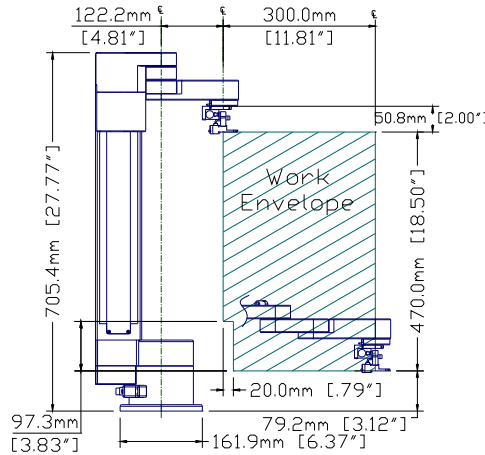

Plan View

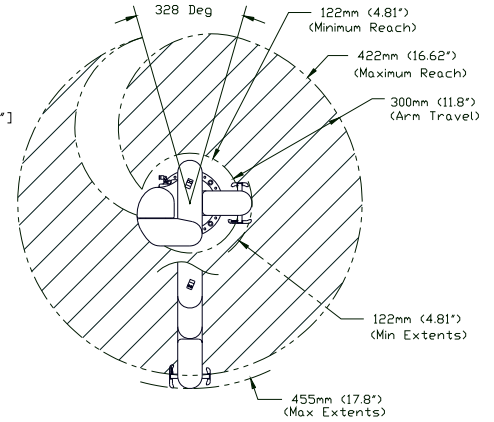

Elevation View

System Options:

- FILO Plate Stacks
- Random Access Plate Hotels
- High Capacity Storage Carousel
- FIFO Plate Stacker
- Extended Z-Axis – 660mm (26")
- Linear Rail (up to 2 Meter travel)
- Integration & Scheduling Software
- "Trailhead" Integration Platform

Specifications:

Max Payload	2 kg (4.4 lb)
Radial Travel, R	300 mm (11.8 in)
Vertical Travel, Z	470 mm (18.5 in), or...
Optional Extended Z:	660 mm (26 in)
Base Rotation, θ	324°
Wrist Rotation, W	330°
Speed (Max):	
Arm Extend	480 mm/s (19 in/sec)
Vertical	450 mm/s (19 in/sec)
Base Rotate	288 deg/sec
Wrist Rotate	380 deg/sec
Repeatability:	
Arm Extend	0.20mm (.008")
Vertical	0.05mm (.002")
Weight:	17 kg (38 Lb)
Power:	24 VDC, 6a In-Line, 100-250 VAC
Compliance:	CE, FCC

Gripper Options:

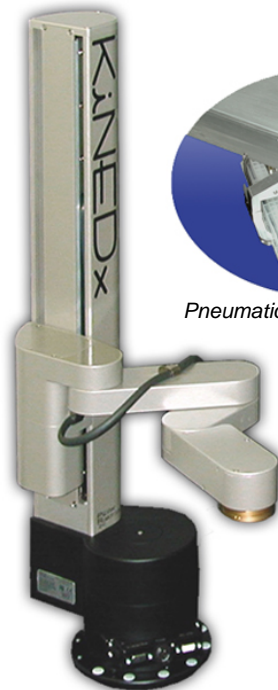

Pneumatic

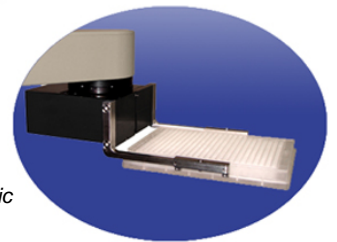

Electric

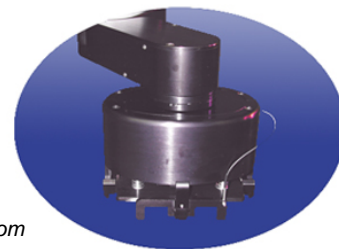

Custom

Printed January 2008